

Service Schematics

NOKIA N85

RM-333/RM-334

Introduction

IMPORTANT:

This document is intended for use by authorized NOKIA service centers only.

“Service Schematics” was created with focus on customer care.
The purpose of this document is to provide further technical repair information for NOKIA mobile phones on Level 3/4 service activities.
It contains additional information such as e.g. “Component finder”.

Saving process time and improving the repair quality is the aim of this document.
It is to be used additionally to the service manual and other training
or service information such as Service Bulletins.

While every endeavour has been made to ensure the accuracy of this document, some errors may exist. If the reader finds any errors, NOKIA shall be notified in writing.

Please send E-Mail to: TrainingAndVendor.Development@nokia.com

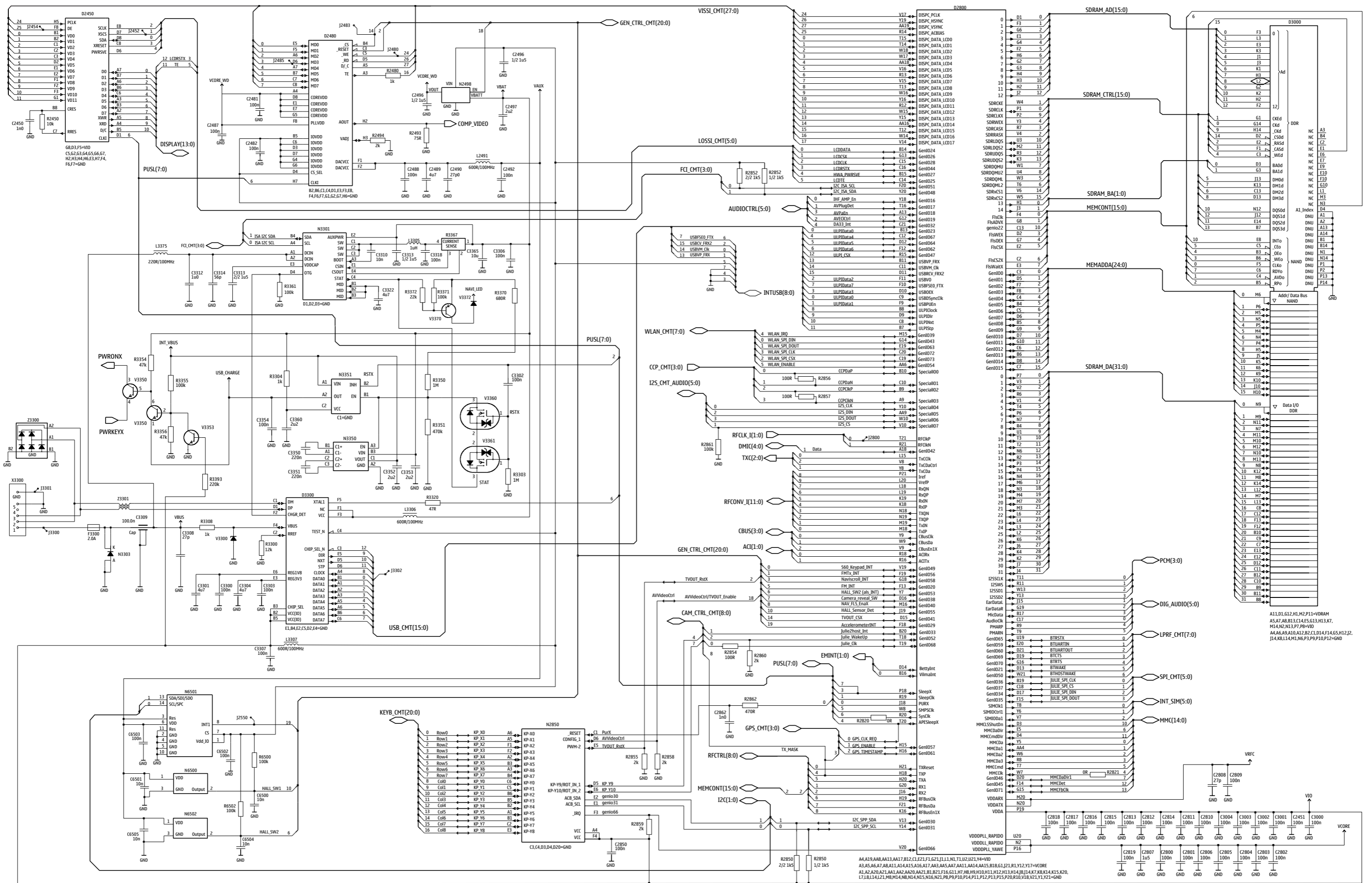

Table of Contents

Front page	1
RAPIDO, memory, USB	2
Betty, AVilma, audio, video	3
Application processor, main camera	4
BTHFM, WLAN	5
GPS, SIM, SD, Flash, FM transmitter	6
Display, camera, keys	7
User Interface (UI)	8
RF part	9
Component finder - Main board	10
Component finder - Sub board	11
Component finder - Slide flexboard	12

Copyright © NOKIA

This material, including documentation and any related computer programs is protected by copyright, controlled by NOKIA. All rights are reserved. Copying, including reproducing, modifying, storing, adapting or translating any or all of this material requires the prior written consent of NOKIA. This material also contains company confidential information, which may not be disclosed to others without the prior written consent of NOKIA.



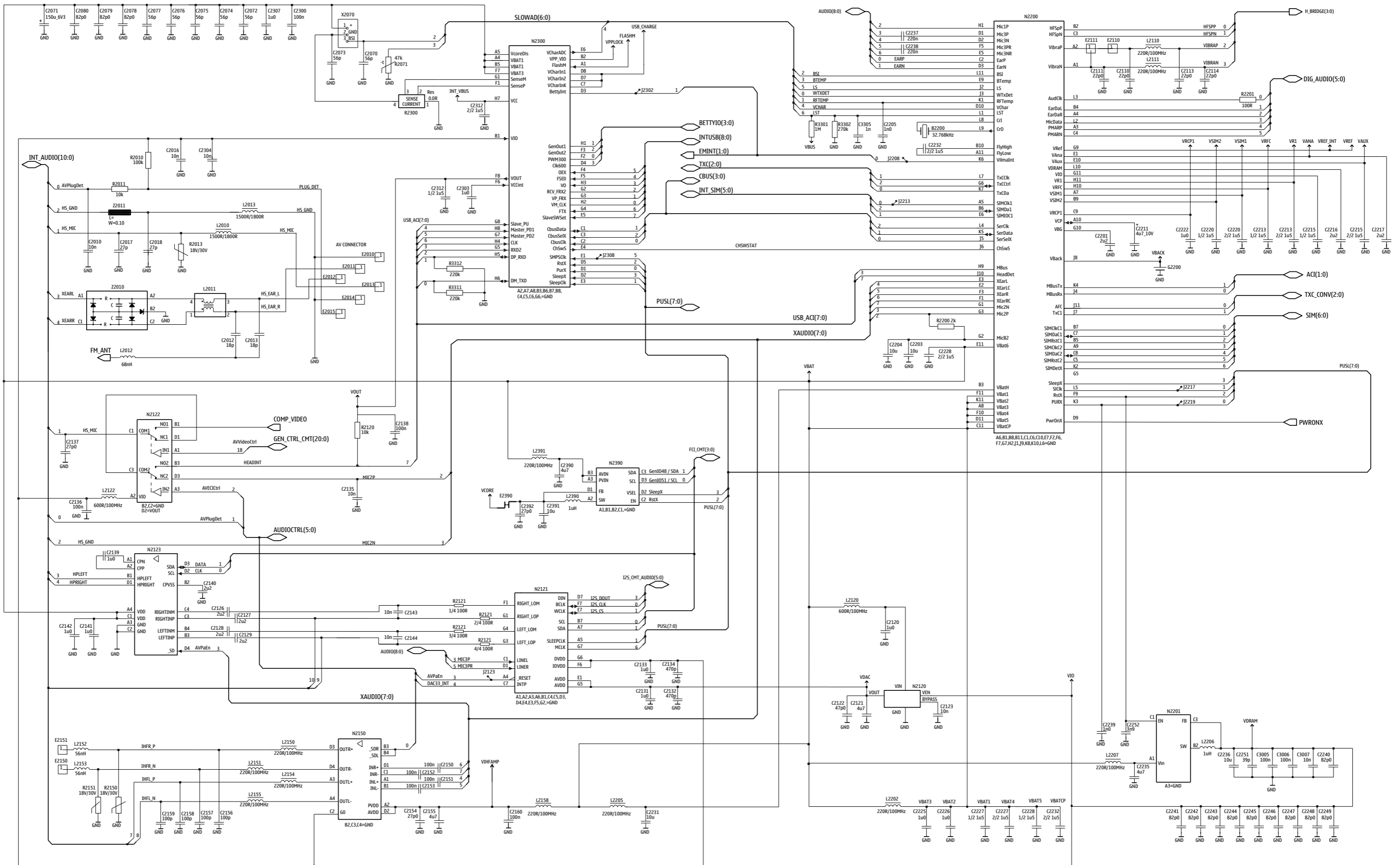

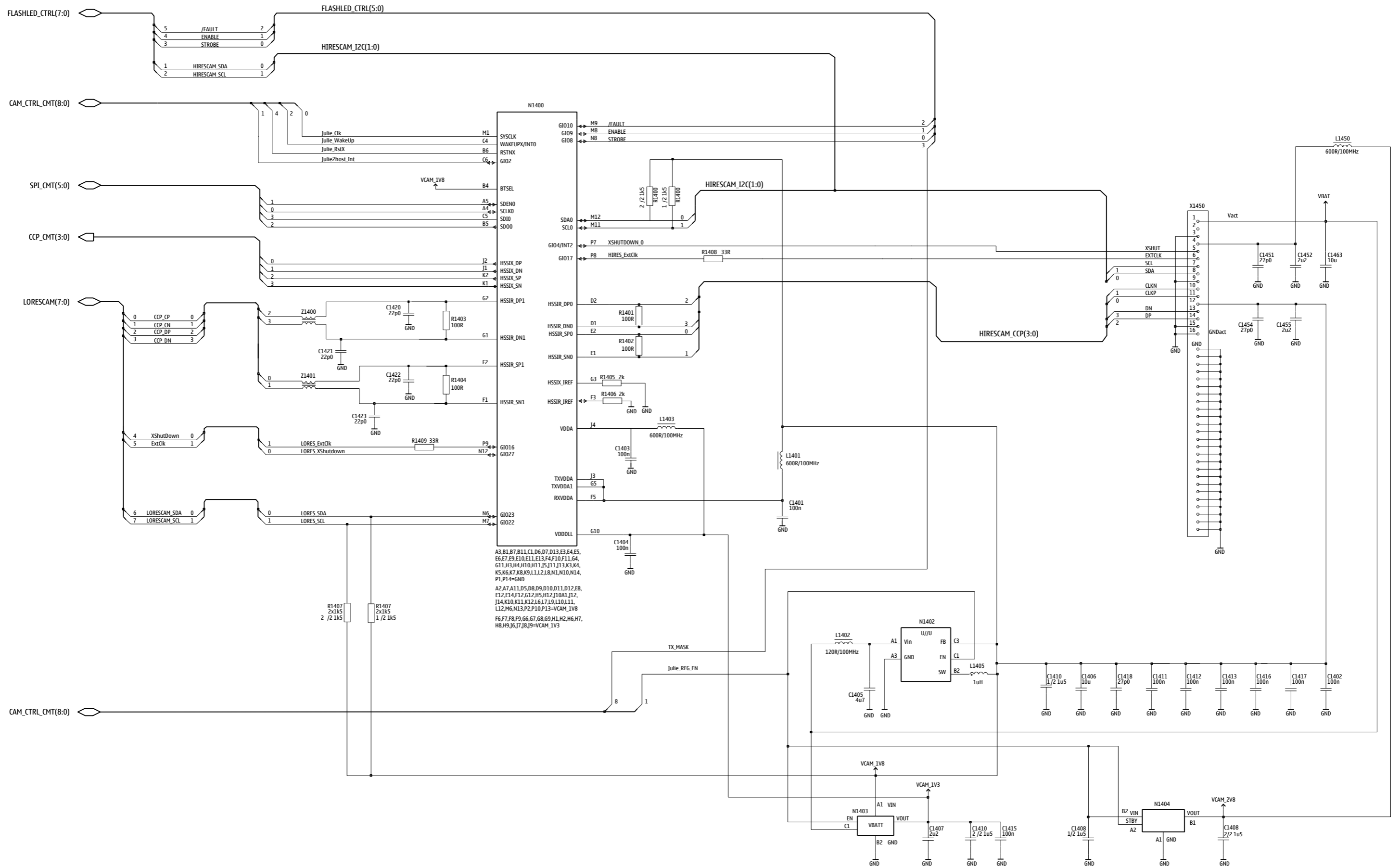

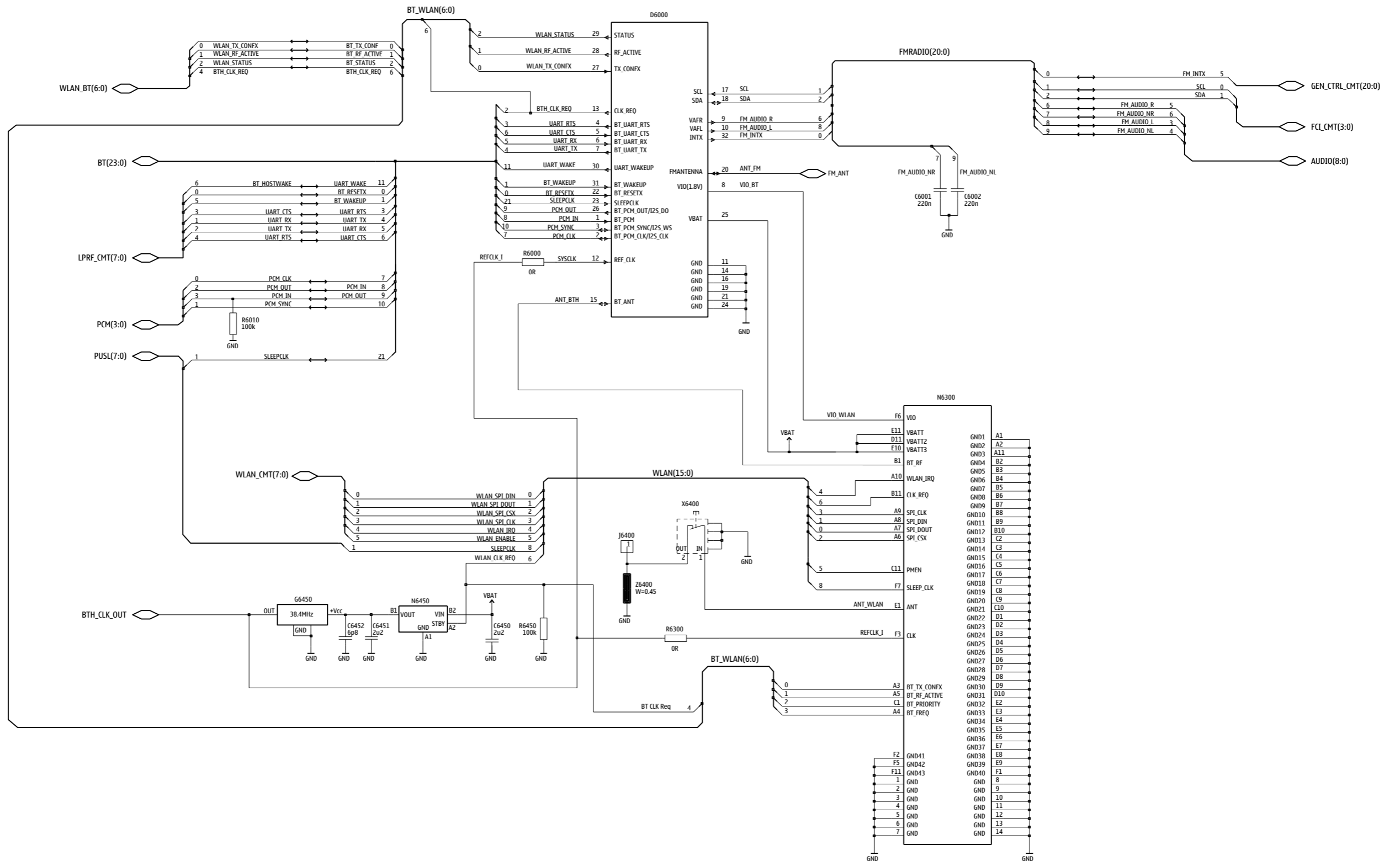

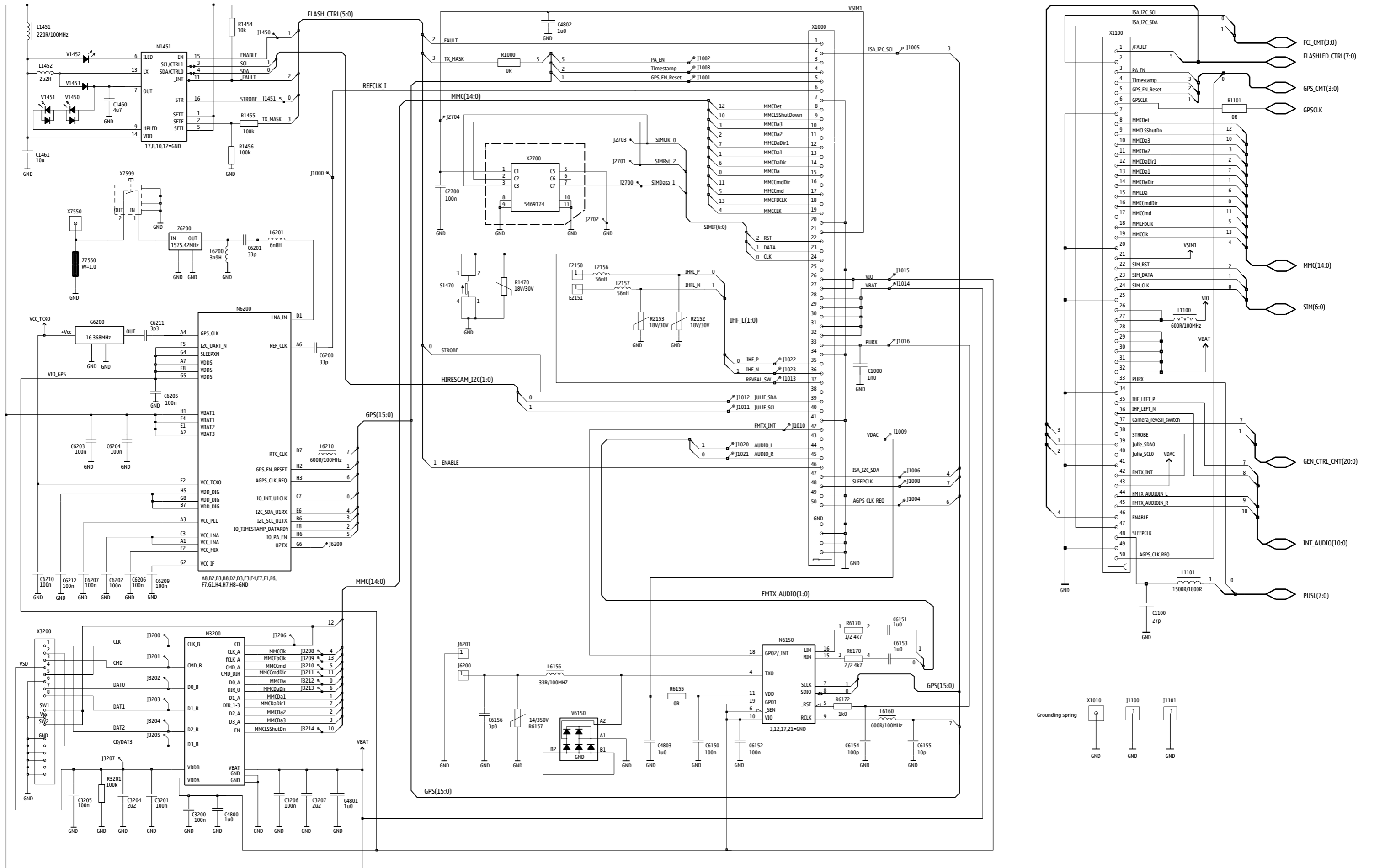

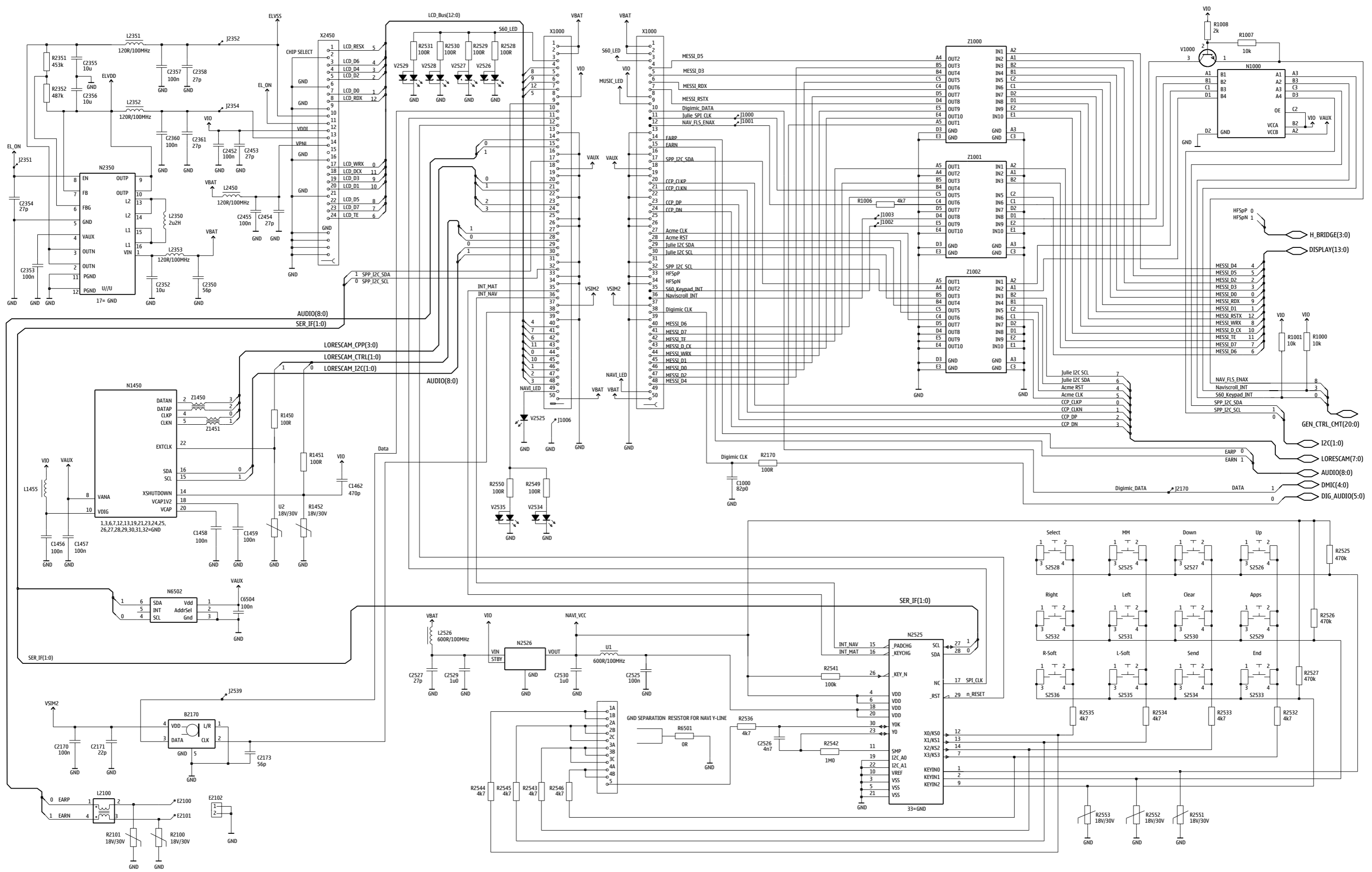

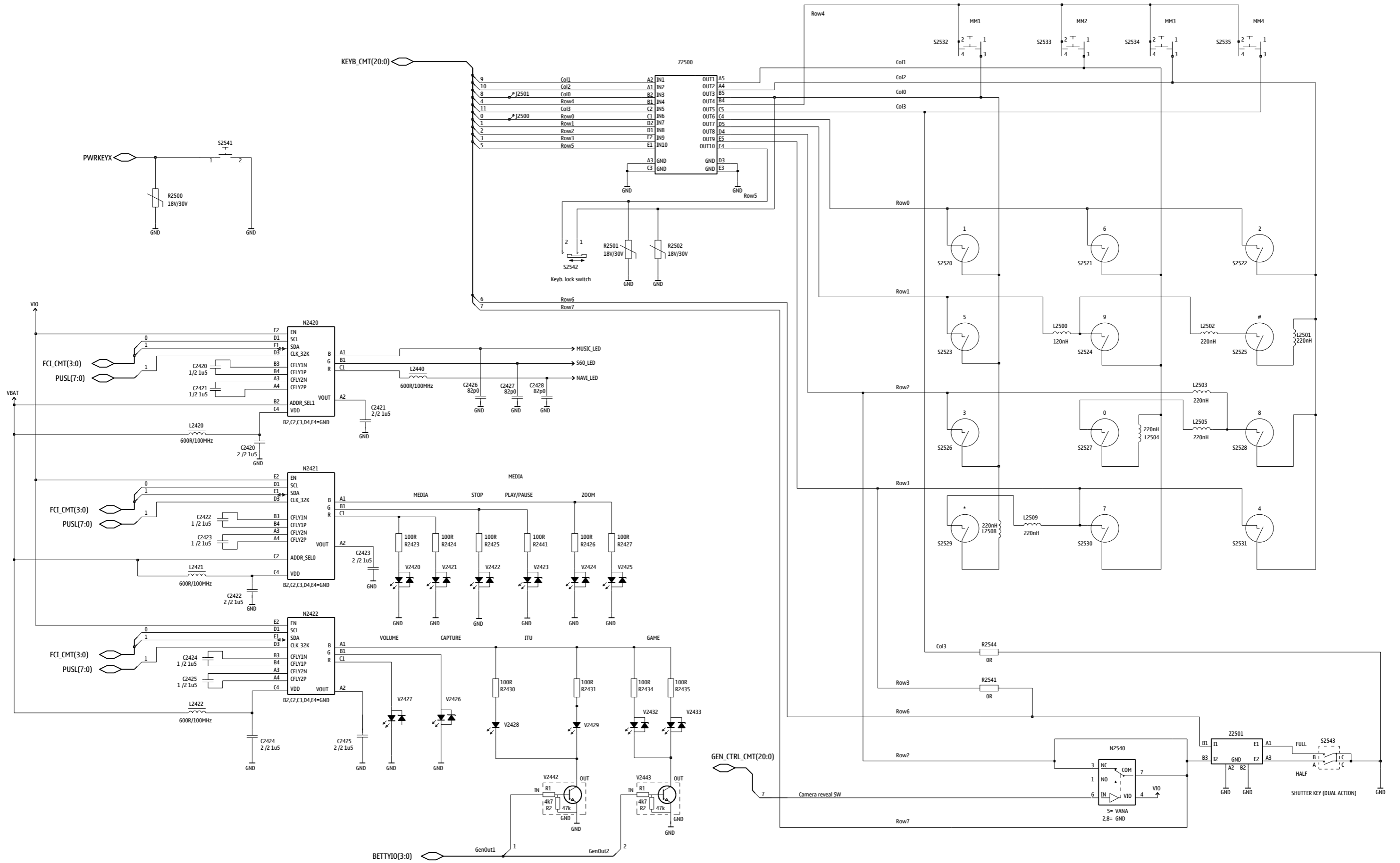

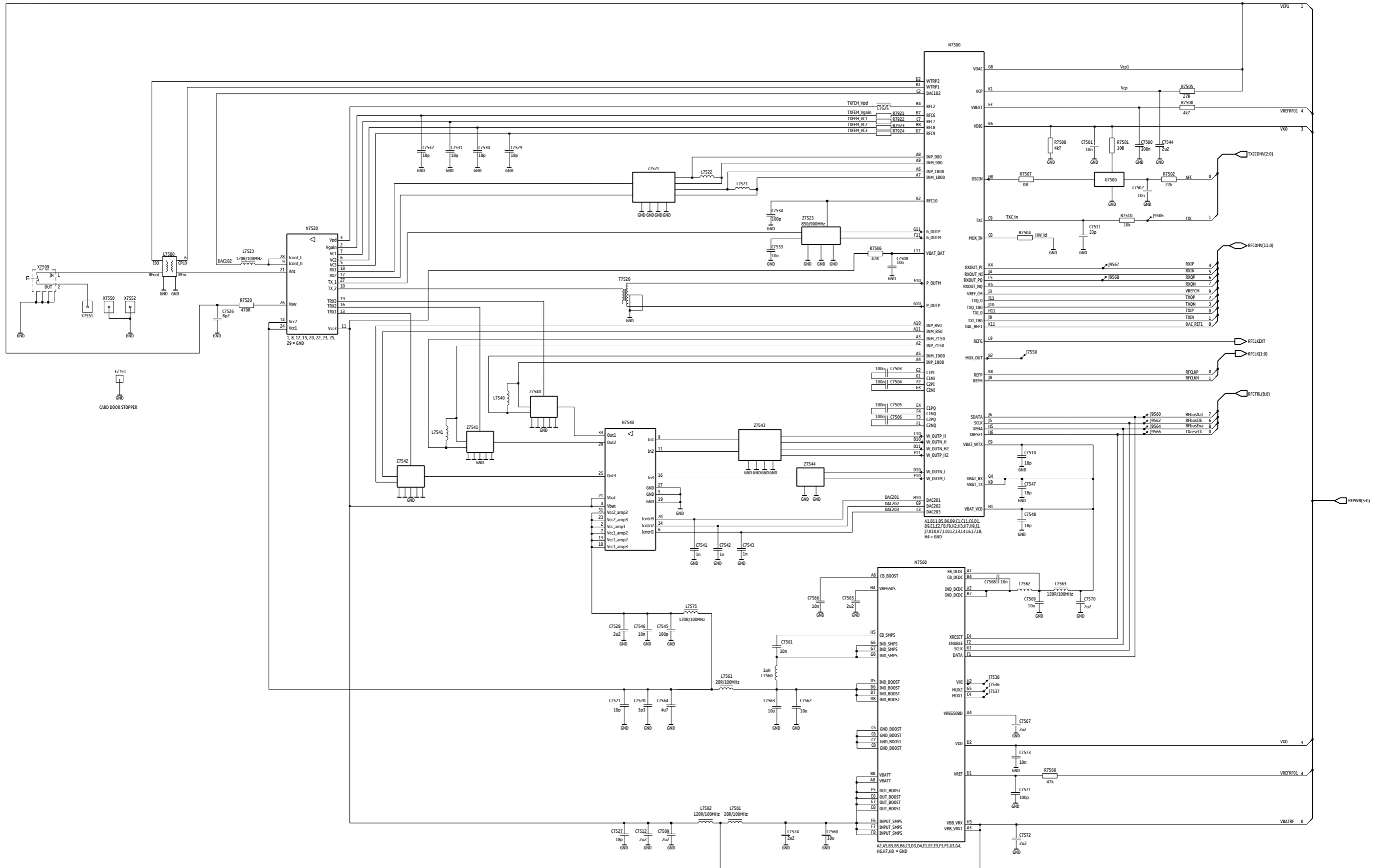

A	C2138	I12	C2428	I8	C6451	B13	E2015	F20	L7540	E8	R2201	H11	R7560	D6	
A3300	I16	C2139	D15	C2450	I8	C6452	C13	E2110	C19	L7541	C8	R2300	D4	R7921	D10
A7500	D8	C2140	E15	C2451	I8	C6500	B3	E2111	C20	L7560	E5	R2423	C20	R7922	D10
B	C2141	D15	C2481	D14	C6501	B3	E2150	H2	L7561	E6	R2424	I20	R7923	D10	
B2200	I11	C2142	D15	C2482	D13	C6502	E16	E2151	G3	L7562	C5	R2425	E20	R7924	D10
C	C2143	E14	C2487	C13	C6503	E16	E7751	B15	L7563	C10	R2426	D19	S		
C1000	I8	C2144	E14	C2488	E14	C6504	B12	F	L7575	E9	R2427	H19	S2532	D20	
C1401	F13	C2150	I13	C2489	E13	C6505	B11	F3300	H19	N	R2430	H7	S2533	F20	
C1402	H13	C2151	I13	C2490	E14	C7500	C11	G	N1000	H9	R2431	E7	S2534	G20	
C1403	F13	C2152	I13	C2492	E14	C7501	E12	G2200	C15	N1400	G12	R2434	F19	S2535	H20
C1404	H13	C2153	I13	C2496	C13	C7502	E11	G6450	C13	N1402	F14	R2435	G19	S2541	D21
C1405	E14	C2154	I13	C2497	D13	C7503	C11	G7500	E11	N1403	H14	R2441	G20	S2542	J12
C1406	F14	C2155	I14	C2800	G9	C7504	C11	J	N1404	E14	R2450	I8	S2543	J6	
C1407	H14	C2156	H13	C2801	H9	C7505	C11	J1100	J15	N2120	G14	R2480	D14	T	
C1408	E15	C2157	I13	C2802	F9	C7506	C11	J1101	B15	N2121	F13	R2493	E13	T7520	E10
C1410	H13	C2158	H13	C2803	G9	C7507	D12	J6400	E20	N2122	I12	R2494	D13	V	
C1411	G13	C2159	H14	C2804	F10	C7508	D12	L	N2123	D15	R2500	D20	V1000	H9	
C1412	G11	C2160	H13	C2805	H10	C7509	C6	L1100	I15	N2150	I13	R2501	I12	V2420	C20
C1413	G13	C2201	J10	C2806	G9	C7510	D11	L1101	G15	N2200	I10	R2502	I12	V2421	I20
C1415	G13	C2203	H11	C2807	F11	C7511	E11	L1401	F13	N2201	G5	R2541	I6	V2422	E20
C1416	G13	C2204	H11	C2808	G11	C7512	C9	L1402	F14	N2300	H5	R2544	I6	V2423	G20
C1417	H11	C2205	H11	C2809	G11	C7520	C7	L1403	G13	N2390	H12	R2820	G11	V2424	D19
C1418	F14	C2211	I9	C2810	G9	C7521	C8	L1405	F15	N2420	J8	R2821	H13	V2425	I19
C1420	F12	C2213	J11	C2811	F9	C7526	E9	L1450	E17	N2421	I6	R2850	H4	V2426	J5
C1421	F12	C2215	J10	C2812	H9	C7527	C6	L2010	G19	N2422	J7	R2852	D14	V2427	J16
C1422	F12	C2216	J11	C2813	H11	C7528	C9	L2011	E19	N2498	D13	R2854	F13	V2428	G7
C1423	F12	C2217	H9	C2814	H9	C7529	E8	L2012	D18	N2540	H9	R2855	J5	V2429	E7
C1451	E17	C2220	I9	C2815	G9	C7530	E7	L2013	G19	N2850	I5	R2856	H10	V2432	E19
C1452	E17	C2222	J10	C2816	I13	C7531	E7	L2110	C21	N3301	J18	R2857	H10	V2433	G19
C1454	H15	C2225	I9	C2817	G11	C7532	E8	L2111	C21	N3303	H19	R2858	I5	V2442	I7
C1455	H15	C2226	J11	C2818	F8	C7533	E8	L2120	G14	N3350	I19	R2859	I5	V2443	I7
C1463	E17	C2227	J10	C2819	G11	C7534	E10	L2122	H13	N3351	I19	R2860	G11	V3300	H16
C2010	G19	C2228	J10	C2850	H5	C7541	E10	L2150	H13	N6300	C17	R2861	F9	V3350	I19
C2012	D19	C2231	H9	C2862	H4	C7542	E10	L2151	I13	N6450	B13	R2862	H4	V3353	H19
C2013	D19	C2232	I9	C3000	F7	C7543	C9	L2152	F4	N6500	B3	R3300	I16	V3360	J19
C2016	G18	C2235	G5	C3001	F10	C7544	C12	L2153	F4	N6501	D16	R3301	H15	V3361	J19
C2017	G19	C2236	F6	C3002	G6	C7545	E9	L2154	I13	N6502	B12	R3302	H15	V3370	I17
C2018	G19	C2237	I11	C3003	H7	C7546	C10	L2155	I14	N7500	D11	R3303	I19	V3372	I18
C2070	E5	C2238	I12	C3004	F8	C7547	C11	L2158	H13	N7520	D7	R3304	I19	X	
C2071	B5	C2239	H11	C3005	F6	C7548	D12	L2202	J11	N7540	D9	R3308	I16	X1000	H8
C2072	C5	C2240	G5	C3006	G5	C7560	E6	L2205	I9	N7560	D5	R3311	H6	X1100	H15
C2073	H4	C2241	I5	C3007	H7	C7561	D5	L2206	G5	R	R3312	G6	X1450	G17	
C2074	J15	C2242	E18	C3300	I16	C7562	E6	L2207	F5	R1000	G11	R3320	J15	X2060	C12
C2075	B11	C2243	C14	C3301	I16	C7563	E6	L2390	I12	R1001	G11	R3350	H19	X2070	C4
C2076	B11	C2244	D14	C3302	I19	C7564	E7	L2391	I12	R1006	H9	R3351	I19	X2110	D20
C2077	G4	C2245	C15	C3303	I16	C7565	D6	L2420	J8	R1007	H9	R3354	I19	X3300	I21
C2078	B11	C2246	I18	C3304	I16	C7566	C5	L2421	I6	R1008	H9	R3355	I19	X6400	D18
C2079	H4	C2247	I13	C3305	H15	C7567	C6	L2422	I7	R1101	D13	R3356	H19	X7550	E3
C2080	B11	C2248	I8	C3306	I16	C7568	C5	L2440	J8	R1400	G15	R3361	J18	X7551	D3
C2110	C20	C2249	I15	C3307	I16	C7569	C6	L2491	E14	R1401	G11	R3367	J18	X7552	C3
C2111	C20	C2251	G6	C3308	H18	C7570	C12	L2500	J3	R1402	F12	R3370	I18	X7599	B6
C2113	H9	C2252	G5	C3309	H19	C7571	D6	L2501	J3	R1403	F12	R3371	I18	Z	
C2114	H9	C2300	H4	C3310	J18	C7572	E5	L2502	I3	R1404	F12	R3372	J17	Z1400	F12
C2120	F14	C2303	H5	C3312	J17	C7573	D6	L2503	F3	R1405	F13	R3393	I18	Z1401	F12
C2121	G14	C2304	J8	C3313	J19	C7574	D5	L2504	E3	R1406	F13	R6000	C16	Z2010	E18
C2122	G13	C2307	H4	C3314	I17	D	L2505	F3	R1407	G13	R6010	F10	Z2500	I5	
C2123	G13	C2312	H5	C3318	I18	D2450	I8	L2508	E3	R1408	G13	R6300	C16	Z2501	I6
C2126	D14	C2390	H12	C3322	I18	D2480	D14	L2509	C3	R1409	G13	R6450	C14	Z3300	G20
C2127	D14	C2391	H12	C3350	I19	D2800	G10	L3305	I18	R2010	G18	R6500	B3	Z3301	H20
C2128	E15	C2392	H11	C3351	I19	D3000	G7	L3306	J17	R2011	G18	R6502	B12	Z7521	D10
C2129	D15	C2420	J8	C3352	I19	D3300	I16	L3307	J17	R2013	G19	R7500	C11	Z7523	E11
C2131	F13	C2421	J8	C3353	I19	D6000	D17	L3375	I17	R2071	J15	R7501	E12	Z7540	D8
C2132	F14	C2422	I6	C3354	I19	E	L7500	C7	R2120	I12	R7502	E11	Z7541	C8	
C2133	F13	C2423	I6	C3360	I19	E2010	G19	L7501	E5	R2121	E14	R7505	C12	Z7542	E8
C2134	F13	C2424	J7	C3601	I9	E2011	F19	L7502	C6	R2150	G4	R7506	E9	Z7543	D10
C2135	H11	C2425	J7	C6005	J19	E2012	F19	L7521	C10	R2151	G4	R7507	E12	Z7544	E10
C2136	H13	C2426	I8	C6002	H9	E2013	F20	L7523	C10	R2170	H11	R7510	E11		
C2137	I13	C2427	I8	C6450	B13	E2014	F21	L7525	C10	R2200	H10	R7520	E7		

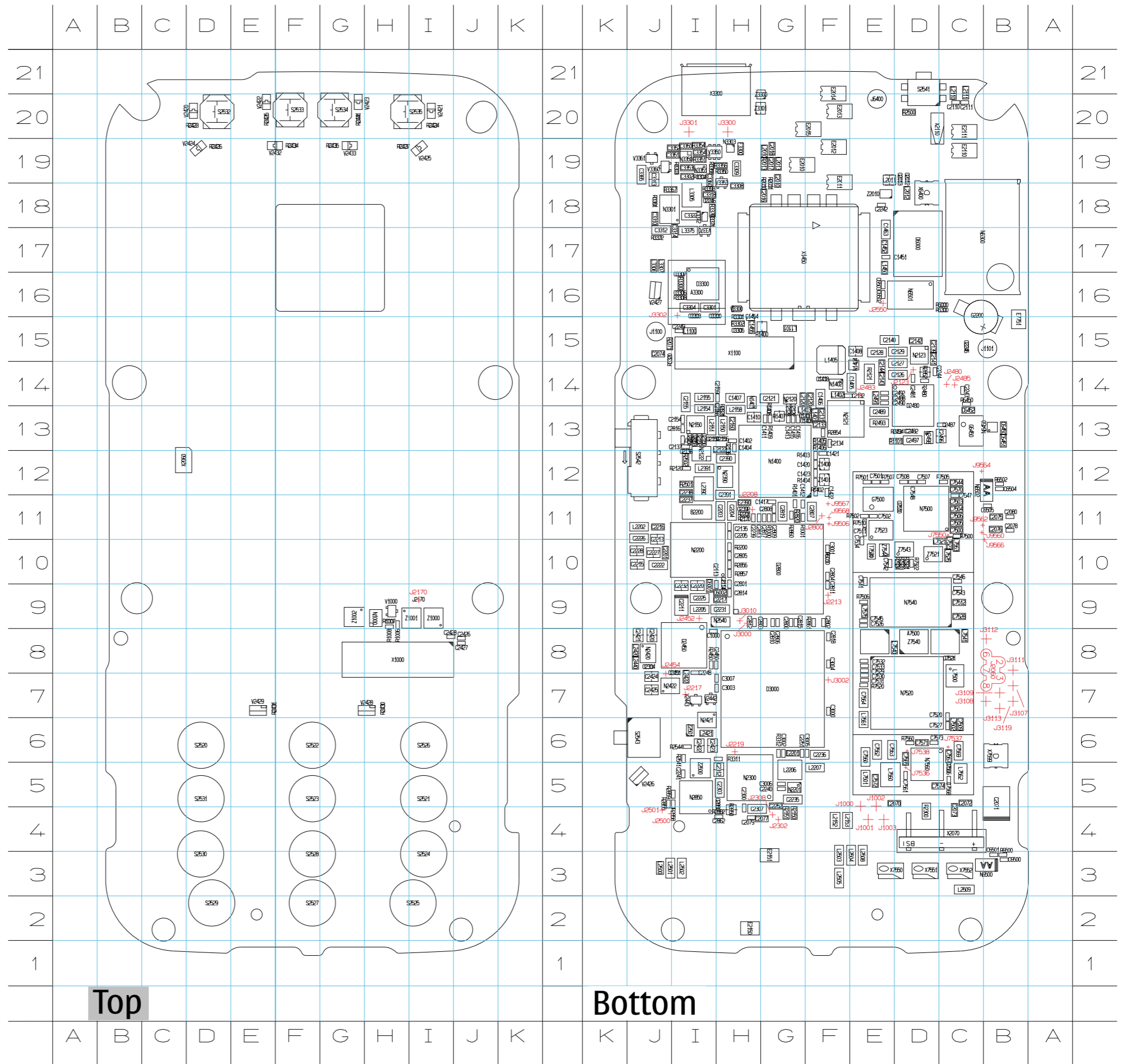

A	J6201	H1	
A3200	C2	L	
A6200	H2	L1451	H6
C	L1452	H6	
C1000	G1	L2156	G6
C1460	G6	L2157	G6
C1461	H6	L6156	I1
C2700	C2	L6160	H2
C3200	D2	L6200	I2
C3201	C2	L6201	I3
C3204	C2	L6210	H1
C3205	C2	N	
C3206	D2	N1451	H6
C3207	D2	N3200	C2
C4800	F2	N6150	I2
C4801	F2	N6200	H3
C4802	E2	R	
C4803	H2	R1000	G3
C6150	H2	R1454	H6
C6151	H2	R1455	I6
C6152	I1	R1456	I6
C6153	H2	R1470	F1
C6154	G2	R2152	G6
C6155	H2	R2153	G6
C6156	I1	R3201	C2
C6200	H3	R6155	H2
C6201	I3	R6157	I1
C6202	H2	R6170	H2
C6203	I3	R6172	G2
C6204	H2	S	
C6205	H3	S1470	F2
C6206	I3	V	
C6207	H3	V1450	H4
C6209	I3	V1451	H3
C6210	I3	V1452	H4
C6211	H2	V1453	G6
C6212	H3	V6150	I2
E	X		
E2150	H5	X1000	E2
E2151	I5	X1010	H7
G	X2700	C4	
G6200	H2	X3200	C4
J	X7550	I3	
J1100	B2	X7599	I3
J1101	I2	Z	
J6200	H1	Z6200	I2

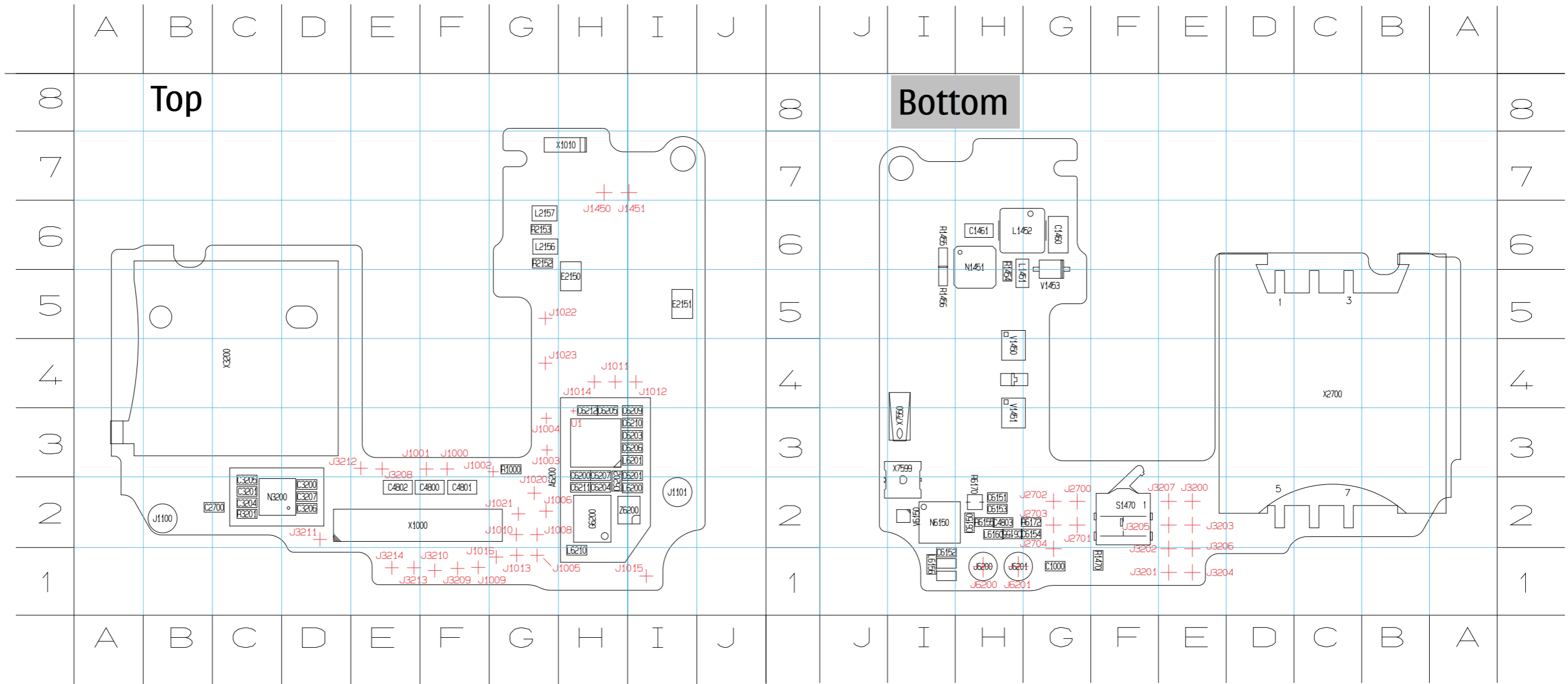

B	C6504	T 28	R2352	R 13	S2529	X 11	
B2170	X 12	E	R2525	W 12	S2530	S 11	
C	E2102	U 29	R2526	V 11	S2531	V 13	
C1456	S 29	J	R2527	W 12	S2532	T 13	
C1457	T 28	J2351	Q 13	R2528	Y 14	S2533	Q 13
C1458	S 28	J2352	R 11	R2529	R 14	S2534	Y 13
C1459	S 28	J2354	S 12	R2530	X 12	S2535	X 14
C1462	S 29	J2539	X 12	R2531	S 11	S2536	S 14
C2170	X 12	L	R2532	V 12	U		
C2171	X 12	L1455	S 29	R2533	U 11	U 1	U 11
C2173	X 12	L2100	W 29	R2534	U 11	U 2	S 29
C2350	Q 14	L2350	R 14	R2535	V 12	V	
C2352	Q 14	L2351	R 12	R2536	W 11	V2525	U 8
C2353	Q 13	L2352	S 12	R2541	W 10	V2526	Y 14
C2354	R 13	L2353	Q 14	R2542	V 12	V2527	R 14
C2355	Q 13	L2450	S 11	R2543	U 11	V2528	X 11
C2356	S 13	L2526	T 11	R2544	T 11	V2529	S 11
C2357	R 12	N	R2545	U 11	V2534	Y 13	
C2358	R 12	N1450	R 29	R2546	U 11	V2535	R 13
C2360	R 12	N2350	R 13	R2549	X 13	X	
C2361	S 12	N2525	V 11	R2550	R 12	X1000	S 25
C2452	T 12	N2526	U 12	R2551	W 14	X2450	R 12
C2453	S 12	N6502	T 29	R2552	W 14	Z	
C2454	S 12	R	R2553	V 14	Z1450	S 28	
C2455	S 12	R1450	S 29	R6501	U 11	Z1451	S 29
C2525	W 10	R1451	T 29	S			
C2526	W 11	R1452	T 29	S2525	S 13		
C2527	T 11	R2100	W 29	S2526	U 14		
C2529	T 12	R2101	W 28	S2527	U 12		
C2530	T 12	R2351	R 13	S2528	U 13		

